

By



Manufacturers and suppliers of all your gravity conveying requirements

MML Conveyors - quality through and through.

- Buy with confidence from a long standing company who prides itself on quality of its products and quality of its service.
- We are a family owned company founded in 1971, staffed by knowledgeable family members with a wealth of experience and understanding of what is important to our customers.
- Our focus on both product and service quality ensures longevity of life for the component and peace of mind for the customer should there be a problem.
- Combine this focus on quality with very quick delivery times, it is no surprise that we have a very loyal customer base with some customers coming back time and time again for over 20 years.
- Give us a try - we hope that you will be impressed by our approachability, knowledge and speed of service.

Gravity rollers and gravity roller conveyors of all types and for all types of industries, manufactured and supplied.

- A gravity roller is a simple, reliable and cheap device.
- Gravity rollers don't need a power input so cost nothing to run.
- Gravity rollers have no motors or chains so there is no need to worry about guarding.
- Gravity rollers only turn when a load is being conveyed - not continuously as in a powered system. Precision bearings are therefore normally not required.
- Gravity rollers allow loads to be easily stopped and started without complex mechanisms to connect/disconnect the power source from the rollers.
- A roller well suited to its application will give years of trouble free service.
- Gravity rollers are available in many different materials for many applications.
- We can supply rollers quickly and efficiently.
- If you want rollers for a lineshaft conveyor, rollers for a chain drive conveyor or drums for a belt conveyor - we may still be able to help.

Thank you for your interest in our Company and its products.



60 mm dia plastic rollers



Plastic roller assortment



48 mm dia plastic skatewheels



Medium, mild steel rollers



Sprocketed steel roller

MML Conveyors range of plastic rollers offer:

- *Quiet running*
- *Low inertia - free running*
- *High cleanliness*
- *Stainless steel ball bearings in thermoplastic races as standard*
- *No lubrication required*
- *Long, trouble free service*
- *Water washable and acceptable in most hygiene environments*

MML Conveyors range of steel rollers and conveyors offer:

- *High durability*
- *Suitable for use in harsh environments*
- *Wide variety of constructions available*



Heavy duty steel rollers



Small, mild steel roller



Mild steel frame and rollers



Metal roller assortment



Mild steel stand for mild steel frames

Contents

| | |
|---------------|---|
| Page 1 | Specification - Large plastic rollers. |
| Page 2 | Specification - Small plastic rollers. |
| Page 3 | Specification - Light duty metal rollers. |
| Page 4 | Specification - Heavy duty metal rollers. |
| Page 5 | Terminology - How we describe roller dimensions. |
| Page 6 | Types of roller fixing - wire locked |
| Page 7 | Contact details |
| Page 8 | Terms and Conditions of sale |

General rules of thumb.

for guidance only.

Always try to select a roller with a capacity near to half the load.

The widest pitch is half the load length - two rollers must be in contact at all times.

For plastic rollers - use a gradient of 2 to 3 degrees (40 to 50 mm of fall per m)

For steel rollers - use a gradient of 5 to 6 degrees (87 to 105 mm of fall per m)

Use the smaller gradient for heavier loads and the larger for lighter loads.

Remember - there is no 'magic' formula for predicting performance. It nearly always comes down to trial and error.

Please visit our Health and Safety guidelines on our website.

www.moving-methods.co.uk/smallprint.htm

All orders are accepted subject to our Terms and Conditions of Sale herein.

Specification - Large Plastic rollers

These free-running gravity roller all share the same bearings giving the same flexibility of fixings for each size. Axle diameters available are 8 mm, 10 mm and 11 mm round or hexagonal across flats in either self colour mild steel or spec 303 stainless steel.

P60



| | |
|-----------------|-------------------------------|
| Roller diameter | 60 mm |
| Width range | 100 mm - 1000 mm |
| Load rating | 25 Kg UDL non impact |
| Materials | Light grey ABS tube, ss balls |

P50



| | |
|-----------------|-------------------------------|
| Roller diameter | 50 mm |
| Width range | 100 mm - 1000 mm |
| Load rating | 20 Kg UDL non impact |
| Materials | Light grey ABS tube, ss balls |

P40

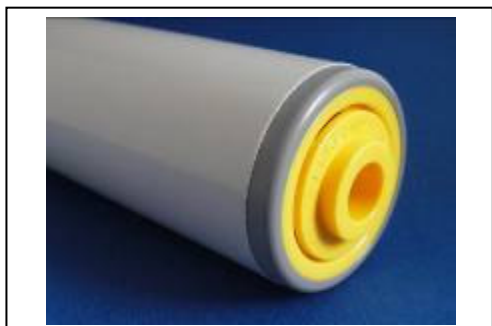

| | |
|-----------------|-------------------------------|
| Roller diameter | 40 mm |
| Width range | 100 mm - 800 mm |
| Load rating | 15 Kg UDL non impact |
| Materials | Light grey ABS tube, ss balls |

Standard axle fixings available are spring loaded (through axle), external thread (M8 or M10), internal tapped (up to M8), wire locking or MML acetal stub axle (this option also allows the bearing to be closed off from the tube with an internal blanking plug to seal against liquid or dust).

Specification - Small Plastic rollers

Axle diameters available are 3 mm, 6 mm and 8 mm round in either self colour mild steel or spec 303 stainless steel.



P30

| | |
|-----------------|--------------------------------------|
| Roller diameter | 30 mm |
| Width range | 100 mm - 650 mm |
| Load rating | 5 Kg |
| | UDL non impact |
| Materials | Light grey ABS tube, stainless balls |



P28

| | |
|-----------------|--------------------------------------|
| Roller diameter | 28 mm |
| Width range | 100 mm - 500 mm |
| Load rating | 3 Kg |
| | UDL non impact |
| Materials | Light grey ABS tube, stainless balls |



P20

| | |
|-----------------|--------------------------------------|
| Roller diameter | 20 mm |
| Width range | 100 mm - 300 mm |
| Load rating | 1 Kg |
| | UDL non impact |
| Materials | Light grey ABS tube, stainless balls |



W28/B

| | |
|---------------------------------|---------------------|
| 28 mm diameter Nylon skatewheel | |
| 26 mm over hubs | 3 mm bore |
| Load rating | 6 Kg UDL non impact |
| Colour | Blue |



W48/R

| | |
|---|----------------------|
| 48 mm diameter Acetal skatewheel | |
| 24 mm over hubs and 15 mm 'tread' width | |
| Load rating | 10 Kg UDL non impact |
| Ball bearings | Carbon chrome |
| Colour | Red |



W48/Y

| | |
|---|----------------------|
| 48 mm diameter Acetal skatewheel | |
| 24 mm over hubs and 15 mm 'tread' width | |
| Load rating | 10 Kg UDL non impact |
| Ball bearings | Stainless steel |
| Colour | Yellow |

Standard axle fixings available are spring loaded (through axle), external thread (M6 or M8), or wire locking. Skatewheels normally have M8 external threaded axles and ABS spacers.

Specification - Light duty Metal rollers

Axle fixings

External thread
Cross drilled
Milled flats
Internal thread
Spring loaded
Steel stub axle (7/16" bore only)

Material options

ms = self colour mild steel (may be available in BZP)
ss = spec 304 stainless tube + spec 420 ss bearing
al = self colour aluminium tube and mild steel bearing

| Diameter | Spindle | Max Load | Material |
|---------------------|-----------|-----------|----------|
| 1" x 18 SWG | 1/4" dia | 10 Kg udl | ms |
| | 5/16" dia | 10 Kg udl | ms |
| | 5/16" hex | 10 Kg udl | ms |
| 1 3/8" x 18 SWG | 5/16" dia | 35 Kg udl | ms |
| | 7/16" dia | 35 Kg udl | ms |
| | 5/16" hex | 35 Kg udl | ms |
| | 7/16" hex | 35 Kg udl | ms |
| | 10 mm dia | 70 Kg udl | ms |
| 1 1/2" x 18 SWG | 7/16" dia | 70 Kg udl | ms,ss |
| | 7/16" hex | 70 Kg udl | ms |
| | 7/16" dia | 50 Kg udl | ms |
| 1 1/2" x 18 SWG | 1/2" dia | 50 Kg udl | ms |
| | 7/16" dia | 60 Kg udl | ms |
| 1 1/2" x 18 SWG | 1/2" dia | 60 Kg udl | ms |
| | 7/16" hex | 60 Kg udl | ms |
| | 10 mm dia | 70 Kg udl | al |
| 2 x 16 SWG | 7/16" dia | 70 Kg udl | al |
| | 10 mm dia | 70 Kg udl | ms,al |
| 2 x 16 SWG | 7/16" dia | 70 Kg udl | ms,ss,al |
| | 5/16" hex | 70 Kg udl | ms,al |
| | 7/16" hex | 70 Kg udl | ms,al |
| | 10 mm dia | 85 Kg udl | ms,ss |
| 2 x 16 SWG | 7/16" dia | 85 Kg udl | ms,ss |
| | 7/16" hex | 85 Kg udl | ms |
| | 10 mm dia | 70 Kg udl | ms,al |
| 2 1/4" x 16 SWG | 7/16" dia | 70 Kg udl | ms,al |
| | 7/16" hex | 70 Kg udl | ms,al |
| | 7/16" dia | 70 Kg udl | ss |
| 60 mm x 2.6 mm wall | 7/16" dia | 70 Kg udl | ss |
| 2 1/2" x 10 SWG | 5/8" dia | 80 Kg udl | al |
| | 7/16" hex | 80 Kg udl | al |
| | 9/16" hex | 80 Kg udl | al |

Please phone or fax for latest prices and specifications

Prices, specifications and credit terms are liable to change without prior notice.

All quoted prices are Ex Works and orders will only be accepted under our standard conditions of sale.

Specification - Heavy duty Metal rollers

Axle fixings

External thread
 Cross drilled
 Milled flats
 Internal thread
 Spring loaded

Material options

ms = self colour mild steel (may be available in BZP)
 ss = spec 304 stainless tube + spec 420 ss bearing
 al = self colour aluminium tube and mild steel bearing

| Diameter | Spindle | Max Load | | Material |
|---------------------|------------|----------|----|----------|
| 2" x 14 SWG | 10 mm dia | 100 | Kg | ms |
| | 7/16" dia | 100 | Kg | ms |
| | 7/16" hex | 100 | Kg | ms |
| 2" x 10 SWG | 7/16" dia | 175 | Kg | ms |
| | 1/2" dia | 175 | Kg | ms |
| | 5/8" dia | 175 | Kg | ms |
| 2 1/4" x 12 SWG | 7/16" dia | 150 | Kg | ms |
| | 1/2" dia | 150 | Kg | ms |
| | 5/8" dia | 150 | Kg | ms |
| 60 mm x 2.6 mm wall | 7/16" hex | 150 | Kg | ms |
| | 7/16" dia | 150 | Kg | ms |
| | 1/2" dia | 150 | Kg | ms |
| | 5/8" dia | 150 | Kg | ms |
| 2 1/2" x 10 SWG | 7/16" hex | 150 | Kg | ms |
| | 5/8" dia | 150 | Kg | ms |
| | 7/16" hex | 150 | Kg | ms |
| 2 1/2" x 10 SWG | 9/16" hex | 150 | Kg | ms |
| | 5/8" dia | 225 | Kg | ms |
| | 3/4" dia | 225 | Kg | ms |
| | 7/16" hex | 225 | Kg | ms |
| 3" x 10 SWG | 9/16" hex | 225 | Kg | ms |
| | 11/16" hex | 225 | Kg | ms |
| | 5/8" dia | 400 | Kg | ms |
| | 3/4" dia | 400 | Kg | ms |
| 3" x 8 SWG | 7/16" hex | 400 | Kg | ms |
| | 7/8" dia | 600 | Kg | ms |
| | 1" dia | 600 | Kg | ms |

Also available as special constructions

- Mild steel rollers in painted frames with painted supports
- Tapered steel rollers
- Rubber covered steel rollers
- Ball tables
- Totally non-metallic rollers
- Totally non-metallic frames
- Grooved rollers for lineshafts
- Sprocketed rollers
- Welded drums
- 4" dia and larger rollers
- Accumulating rollers

Please enquire for specifications, prices and availability.

Terminology

Gravity conveyors with plastic rollers or wheels

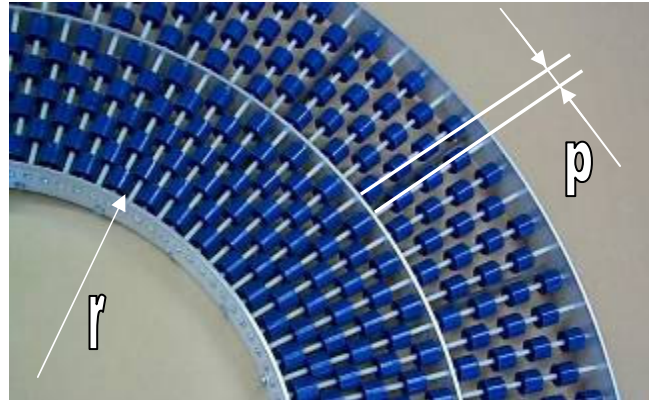
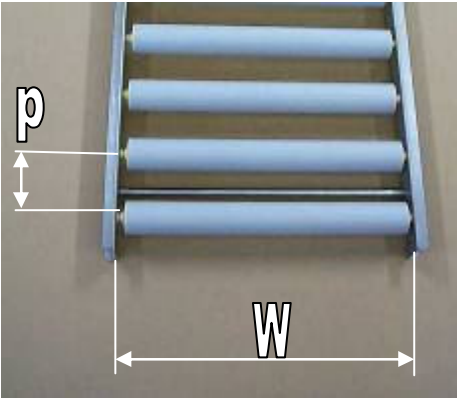

P = pitch r = inside radius W = inside frame R = Centreline radius [R = r + (W/2)]

Rollers

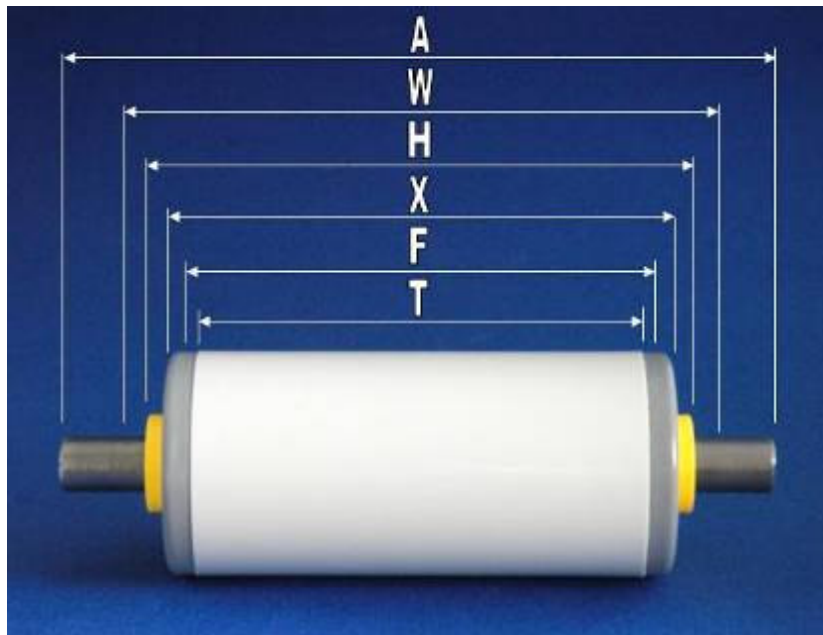

| A | W | H | F |
|---------------------------|------------------------|-----------------------|----------------------|
| Axle length | Inside Frame | Over hubs | Face length |
| Spindle length | Between brackets | Over hub projection | <i>Roller length</i> |
| Shaft length | Gap | <i>End to end</i> | |
| Rod length | Face dimension | <i>Overall length</i> | |
| <i>Overall length</i> | <i>Between flanges</i> | <i>Roller length</i> | |
| | | <i>Face length</i> | |
| X | T | | |
| <i>Face to face</i> | <i>Tube length</i> | | |
| <i>Roller length</i> | <i>Pipe length</i> | | |
| <i>Over bearing faces</i> | | | |
| <i>Face length</i> | | | |

This table shows commonly used nomenclature and the dimensions to which they refer.
Please avoid the phrases in red italics as they are too prone to misunderstanding.

Roller Fixings Explained

Spring loaded

Depress one end of the shaft until flush.
 Locate the extended end in the frame.

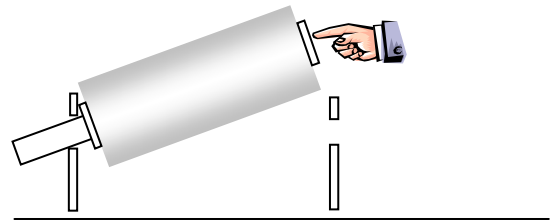

Release the shaft as it goes in.
 It will pop out of the hole as it aligns.

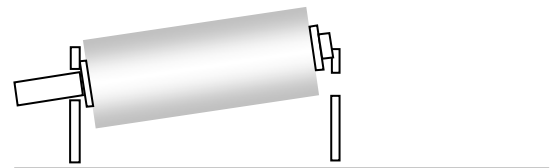

Stub axle

Use spanners to hold the stub axle on
 the inside of the frame.
 Use spanners to run screw through the
 frame and into the stub axle.



Wire locked

Pull shaft out of the roller.
 Put roller in the frame.
 Re-insert the shaft.
 Put split pins through the shaft holes
 or wire adjacent shafts together.

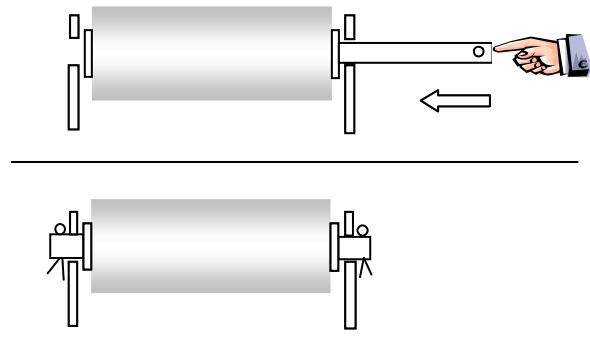

External thread and nuts

Remove one of the nuts.
 Pull shaft out of the roller.
 Put roller in the frame.
 Re-insert the shaft.
 Re-attach the loose nut.
 Tighten lightly with spanners.

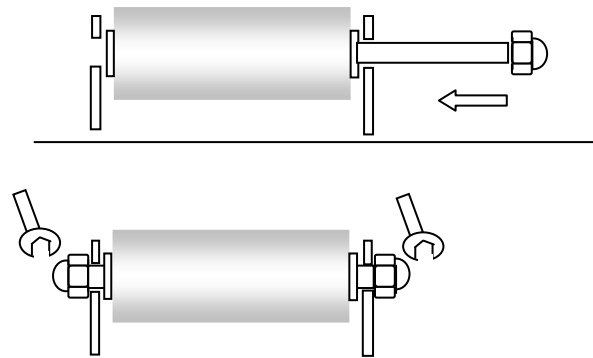

Contact us with your requirements

By Telephone on 01606 833262

By Facsimilie on 01606 832304

By email on steve@moving-methods.co.uk



Via our website at www.moving-methods.co.uk

By post at

MML Conveyors
Brooks Lane
Middlewich
Cheshire
CW10 0JH

Don't forget:

- The quality of our product.
- The quality of our customer service.
- The quality of the materials we use.

We know that customers want the right product at the right time -

Give us a ring, give us a try.

Ask for Steve or Andy - we have over 40 years of experience between us in the business!

CONDITIONS OF SALE

Version A.

CONDITIONS OF CONTRACT: governing all contracts for the sale or supply of goods by Moving Methods Limited ("the Company").

In these conditions:

"Buyer" means any person at whose request goods are supplied by the Company; and "goods" means any goods or replacements thereof supplied to the Buyer under the conditions of sale.

These Conditions shall apply to every contract entered into with the Company except as varied by express agreement in writing signed by a director or authorised person on behalf of the Company. The headings are for convenience only and shall not affect construction of these conditions.

1. FORMATION AND PARTIES

(a) The Buyer's order to the Company is an offer to enter into a contract upon these Conditions. Any terms or conditions proffered at any time by the Buyer are hereby excluded.

(b) The Buyer shall not assign the benefit of the contract without the Company's prior written consent.

(c) The contract is not cancellable by the Buyer without express written consent of a director or other authorised person on behalf of the Company and only on terms which will indemnify the Company against loss.

2. PRICE

(a) The Prices quoted are in accordance with the Company's current price list and exclusive of Value Added Tax. Except where stated by the Company to the contrary the Price excludes packaging and delivery.

(b) The Company reserves the right to vary the price of the goods by any amount attributable to a suspension of or alteration to work by reason of a change in the Buyer's instructions or a lack of instructions or any variation in cost of materials/labour duties taxes exchange rates or any costs of whatsoever nature between the date of the contract and the date of delivery or completion of payment.

(c) Quotations indicate the price at which the Company would be willing to do the work or supply goods if an order is placed in 30 days. They are not offers to do work or supply goods and any order placed on the basis either of a quotation or of the Company's standard price list must be accepted by the Company for a contract to arise.

3. DELIVERY

(a) Delivery dates are estimates only and the time of delivery is not of the essence of the contract. The Company shall use its reasonable endeavours to deliver the goods by the stated delivery date, but may suspend or delay delivery and shall not be liable for any loss whatsoever in the event of late delivery or non-delivery of goods or any instalment owing to any occurrence whatsoever beyond its control. The Buyer shall not be entitled to refuse to accept late delivery or treat late delivery as a breach of contract.

(b) The Company may at its option deliver by instalments, and each instalment shall constitute a separate contract on these Conditions.

(c) Delivery shall take place and risk shall pass upon the earliest of the following:-

(i) the Company handing the goods to the Buyer or its agent at the Company's premises; or

(ii) the goods leaving the Company's premises; or

(iii) the expiry of (in the case of inland orders) the seventh working day or (in the case of export orders) the fourteenth working day after notification by the Company to the Buyer that the goods are available for collection at the Company's premises;

(iv) If the Buyer shall fail to collect the goods on the expiry of the seventh working day following notification as provided for in paragraph 3c(iii) above, the Company shall be at liberty to treat the contract as repudiated by the Buyer. Until the contract is so terminated the Company may store the goods, the cost of storage being added to and form part of the price.

If the Company elects to treat the contract as repudiated in accordance with this Condition it shall (without prejudice to its rights and remedies against the Buyer in respect of such repudiation) be at liberty to sell the goods and retain the proceeds thereof.

4. LOSS OR DAMAGE IN TRANSIT

The Buyer shall notify the Company and the carrier of loss or damage to the goods in transit within twenty four hours after receipt and in writing within seven working days after despatch.

5. DESPATCH

(a) The Buyer shall inspect the goods immediately upon delivery and subject to paragraph (b) below be deemed; to have accepted the goods as delivered.

(b) The Company shall not be liable for defects or shortages discoverable on reasonable inspection unless the Buyer notifies the Company before the expiry of seven working days after delivery of any alleged defect or lack of conformity with the contract.

(c) The Company shall make good shortages (in excess of the permitted margins) notified to it under paragraph (b) as soon as reasonably practicable but shall not be liable for any other loss whatsoever arising from such shortage.

(d) The Company's liability for goods lost or damaged in transit shall in all circumstances be limited to (at the Company's option) repair or replacement or crediting the Buyer with the invoice value of the goods in question.

6. CANCELLATION

Goods returned without the Company's consent will not be accepted for credit. Where goods are returned with the Company's consent by prior arrangement in writing all costs of carriage shall be paid by the Buyer and a minimum restocking charge of 50% of the invoice value of the goods shall be made, provided always that it shall be the responsibility of the Buyer to return the goods to the Company in good and saleable condition at the Buyer's risk.

7. WARRANTY

(a) If within six months after delivery a material defect in the goods shall be discovered:-

(i) The Buyer notifies the Company within that period giving particulars and at its own expense returns the goods to the Company; and

(ii) such defect has arisen from faulty materials employed or workmanship carried out by the Company existing but not discoverable upon inspection at the time of delivery, then the Company shall supply replacements or, at its option, credit the Buyer's account with the Company or refund to the Buyer the purchase price paid for (and cost of returning) the defective goods.

(b) The Company's liability for defective goods is limited in all circumstances to (at the Company's option) delivery of replacements or crediting or refunding of the invoice value to the Buyer and the Buyer shall accept such of the aforementioned remedies as the Company shall proffer as being fulfilment of the Company's obligations under the contract. These Conditions shall apply mutatis mutandis to any replacement goods supplied by the Company.

(c) The Company's liability under this Condition applies to defects appearing before the Buyer makes any modification or alteration to the goods and whilst the goods are properly used or stored and in particular (but without limitation) the Company shall not be liable in the case of defects arising from normal deterioration or improper or faulty handling or processing by the Buyer.

8. ITEMS SUPPLIED BY THE BUYER

The Buyer shall be liable for all drawings specifications and instructions issued to the Company with orders or pursuant to the contract and shall indemnify and keep indemnified the Company against all loss directly or indirectly arising out of any error or omission from such drawings specifications and instructions, and all costs claims demands and expenses whatsoever in respect of the infringement or potential infringement of any patent copyright, registered design or third party right arising out of the Company's use of such drawings specifications or instructions.

9. LIMITS OF LIABILITY

(a) The goods are supplied strictly on the terms that the Buyer has satisfied itself of their suitability for its purposes. The Buyer acknowledges that all specifications and details in catalogues, quotations and acknowledgements of order or similar documents or by word of mouth and all forecasts of performance howsoever given are approximate only and do not form part of the contract and that in respect of such specifications details and forecasts the Company shall be under no liability nor shall the buyer be entitled to any remedy under any provision of the Misrepresentation Act 1967.

(b) The Company's liability under Conditions 5&7 shall be accepted by the Buyer in lieu of any warranty or condition, whether express or implied by law, as to the quality or fitness for any particular purpose of the goods and save as provided in these Conditions the Company shall not be under any liability to the Buyer (whether in contract, tort or otherwise) for any defects in the goods, materials supplied or workmanship performed by the Company or for any damage, loss, death or injury resulting from such defects and the Buyer shall indemnify the Company against any claims in respect thereof. For the purposes of this paragraph the Company contracts on its own behalf and on behalf of and as trustee for its sub-contractors, servants and agents.

(c) The Company shall not be liable, whether by way of indemnity or by reason of breach of contract, tort or breach of statutory duty or in any other manner for consequential or indirect loss of whatever nature suffered by the Buyer or for special damages, loss of use, (whether complete or partial) of the goods or loss of profit or of any contract.

(d) Nothing in this Condition shall be construed as limiting or excluding the Company's liability for death or personal injury resulting from its negligence (as defined in section 1 of the Unfair Contract Terms Act 1977).

(e) No part of the contract shall confer or be intended to confer a benefit on any third party for the purposes of the Contracts (Rights of Third Parties) Act 1999 or for any other purpose.

10. RETENTION OF TITLE

(a) Until the Company has received payment in full of all sums owed to it on any account by the Buyer (whether arising out of this or any other contract):-

(i) title of the goods shall remain in the Company; and

(ii) the goods shall be at the Buyer's risk and the Buyer shall from the date of delivery at its own expense effect insurance of the goods for their full replacement value against all usual risks; and

(iii) the Buyer shall take due care of the goods and store them separately and clearly identifiable as the Company's property and shall not remove alter or deface identification marks on the goods or (if supplied in prepacked form) on the packaging of the goods; and

(iv) subject to paragraphs (v) and (vi) below the Buyer may use and otherwise deal with and in its own name (but not on behalf of the Company) sell the goods in the ordinary course of business on the basis that the proceeds of the sale shall belong to the Company; and

(v) the Buyer shall hold the proceeds of the sale of goods sold pursuant to the power of sale in paragraph (iv) above on trust for the Company absolutely and shall not pay them into an overdrawn bank account nor allow such proceeds to be withdrawn or charged and shall keep them at all times identifiable as the Company's monies; and

(vi) sales of the goods pursuant to this Condition shall be at their full market value and in the case of goods which have been processed by the Buyer or combined with other goods not the property of the Company the Buyer shall hold on trust for the Company such proportion of the proceeds of the sale as is attributable to the Company's goods; and

(vii) the Company may at any time by notice to the Buyer revoke or suspend the Buyer's power of sale and use:-

1. if the Buyer is in default for longer than 14 working days in the payment of any sum whatsoever due to the Company; or

2. if any negotiable instrument drawn by the Buyer in favour of the Company is dishonoured on presentation for payment; or

3. if the Company has reasonable doubts as to the ability or willingness of the Buyer to pay any sum to it on the due date; and

(viii) the Buyer's power of sale and use shall automatically determine if the Buyer becomes insolvent or commits any act of bankruptcy or causes a meeting of or makes any arrangement or composition with creditors or has an administrator appointed over any of its assets or undertaking or a winding up order is made against it or goes into voluntary liquidation or if there is presented a petition for its winding-up (otherwise than for a bona-fide reconstruction or amalgamation) or for the appointment of an Administrator or Administrative Receiver; and

(ix) the Company may at any time on giving prior notice enter the Buyer's premises for the purpose of inspecting the goods and identifying them as the Company's property and the Buyer irrevocably authorises the Company to enter upon its premises for that purpose; and

(x) notwithstanding that in exercise of its right to use the goods, the Buyer may attach or incorporate the goods in other goods, the resulting product ("the Product") shall belong legally and beneficially to the Company, and to any other owner whose goods have been incorporated in the Product, in common. The Company may require the Product to be sold in order to recoup the monies owed to it and the Buyer shall hold all proceeds in trust for the Company and the other owner(s) proportionally to the value of their respective goods incorporated in the Product. The forgoing provisions of this Condition shall be construed as applying to Products in the same manner as to goods title to which has not passed.

(b) Upon suspension revocation or determination of the Buyer's power of sale and use under this Condition the Buyer shall place all the goods in its possession or under its control at the Company's disposal and shall irrevocably authorise the Company to enter upon any of the Buyer's premises, with or without vehicles, for the purpose of removing such goods.

(c) The repossession of goods by the Company in accordance with this Condition shall be without prejudice to all or any of the Company's other rights against the Buyer under contract.

11. PAYMENT

(a) Subject to satisfactory trade, banker's and other requisite references and, where no other terms of payment have been specifically agreed in writing, the Company's terms are cash payment in full to be made at the end of the month following the invoice date. No discount or allowance will be made unless specifically stated by the Company in writing.

(b) Time for making payment shall be of the essence of the contract.

(c) The Company may at any time at its absolute discretion appropriate any payment made by the Buyer in respect of goods to such outstanding debt as the Company thinks fit notwithstanding any purported appropriation to the contrary by the Buyer.

(d) The Company shall be entitled to cancel the contract or to postpone any delivery until payment has been received in the event that the Company has reasonable doubts about the Buyer's ability or willingness to pay on the due date.

(e) The Company reserves the right at any time at its discretion to demand security for payment before continuing with an order or delivering goods or any instalment.

(f) VAT will be charged at the rate ruling at the time of despatch of the goods or, if different, the basic tax point (as defined in regulations governing VAT from time to time in force).

(g) The company shall be entitled to interest as well as payment on any part of the Contract price not paid by the due date from that date until actual payment at a rate of 5 per cent per annum above the Base Lending Rate of The Royal Bank of Scotland prevailing from time to time during such period.

12. FORCE MAJEURE

(a) The Company shall not be liable to the Buyer if unable to carry out any provision of the Contract for any reason beyond its control including (without limitation) Act of God, legislation, war, civil commotion, fire, flood, drought, failure of power supply, lock out, strike, stoppage or other action by employees or third parties in contemplation or furtherance of any dispute or owing to any inability to procure parts or materials required for the performance of the contract.

(b) The Company shall notify the Buyer as soon as reasonably practicable after circumstances preventing performance arise. During the continuance of such a contingency the Company may, within its absolute discretion, withhold, reduce or suspend performance of its contractual obligations so far as prevented or hindered by such contingency without liability to the Buyer for any loss or damage whatsoever suffered directly or indirectly by reason of any such withholding, reduction or suspension.

(c) Should such contingency continue for more than three months either party may (subject to the Company repaying to the Buyer any advance payments made for undelivered goods and the Buyer paying for goods delivered) cancel the contract without further liability to the other.

13. NO WAIVER

No waiver of any of the Company's rights under the Contract shall be effective unless in writing signed by a Director or other authorised person on behalf of the Company. A waiver shall apply only to the specific circumstances in which it is given and shall be without prejudice to the enforcement of a Company's rights in relation to different circumstances or the recurrence of similar circumstances.

14. NOTICES

Any notice under these Conditions shall be properly given if in writing and sent by first class post or facsimile to the address of the intended recipient as stated in the contract or to such address as the Company and the Buyer from time to time notify to each other as their respective addressees for service and shall be deemed served in the case of postal notice, on the expiry of 48 hours from time of posting and in the case of facsimile, on expiry of 15 minutes from completion of successful transmission by the sender.

15. CONSTRUCTION AND JURISDICTION

(a) English Law shall govern construction and operation of the contract and the Buyer agrees to submit to the non-exclusive jurisdiction of the English Courts.

(b) Each of these Conditions and each paragraph hereof shall be construed as a separate condition. Should any provision hereof be found to be invalid or unenforceable or an unreasonable restriction to the Company's liability then such provision shall apply with such modification as may be necessary to make it valid and effective.

M M L Conveyors
Brooks Lane
Middlewich
Cheshire CW10 0JH
England

Telephone: 01606 833262 Facsimile: 01606 832304

E-Mail: steve@moving-methods.co.uk

More information is available on our web site:

www.moving-methods.co.uk

M M L Conveyors is a trading name of Moving Methods Limited

